

Exemple de contrôles avec les Caméras Pictor V&C

Contrôle du vissage

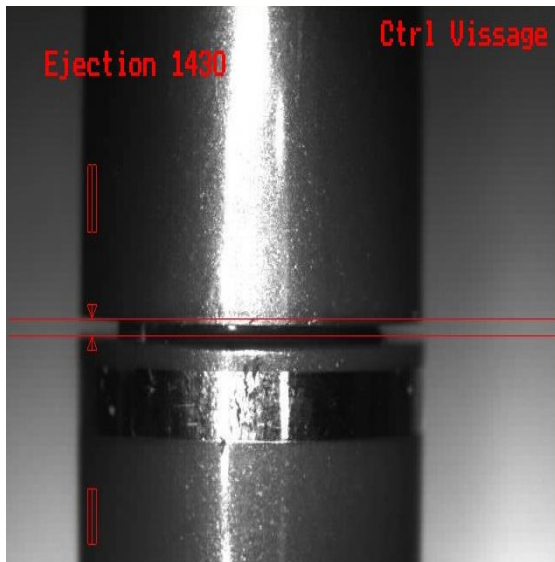

Mesure de joints

mesure de joints

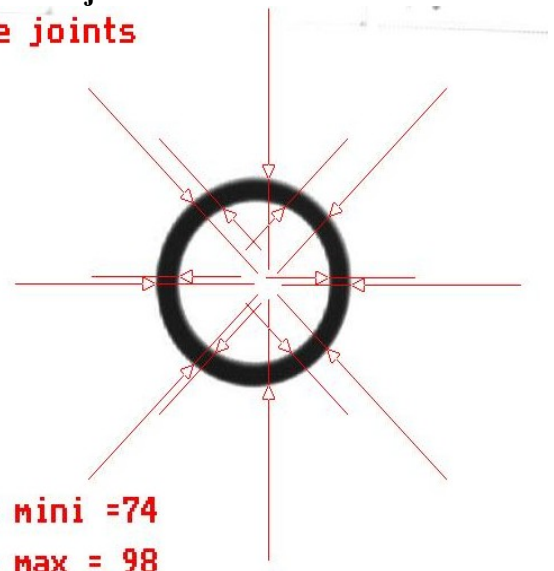

Contrôle de spot

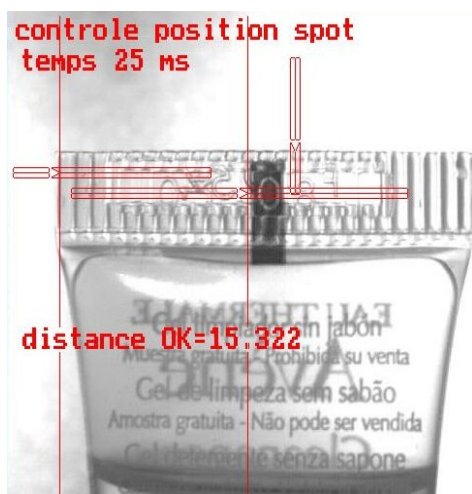

Contrôle de niveau

